

400 SBRZ, 600 SBRZ, 400 TBTZ, 400 MBRZ Mass-Centering Machines for Crankshafts



- Modular design, change over for various crankshaft types through different carriages
- Fully automatic operating sequence
- Direct integration with production lines
- Processing of unbalance data from the final balancing machine for optimization of the manufacturing process

Range of application

Mass-centering of face milled raw crankshaft castings or forgings in a variable program.
Processing of symmetrical and asymmetrical crankshaft types by change over.
Conceived for use by engine manufacturers in mid-volume and high-volume production.
Manual loading and unloading of the machine by lifting device or automatically by interfacing with customer's conveying equipment. Integration of preceding or subsequent process steps in the complete line.

Design

Mingle or multi-station machines with automatic sequence. Loading and unloading manually with a suitable lifting device, automatically by loading gantry or by integrated lift and carry transport.

Flexible machine design, especially suitable for varying crankshaft programs. Manual or automatic length adjustment for change-over to various crankshaft lengths. Balancing frame supported on the machine base by round springs. Two carriage units mounted on the balancing frame with integrated externally rotating end discs mounted on precision bearings, each with two adjusting gears. Hydraulic spindle drill units or electro-mechanical carriage drill for center drilling, either integrated into the measuring station or arranged in a separate centering station.

400 SBRZ, 600 SBRZ, 400 TBTZ, 400 MBRZ Mass-Centering Machines for Crankshafts

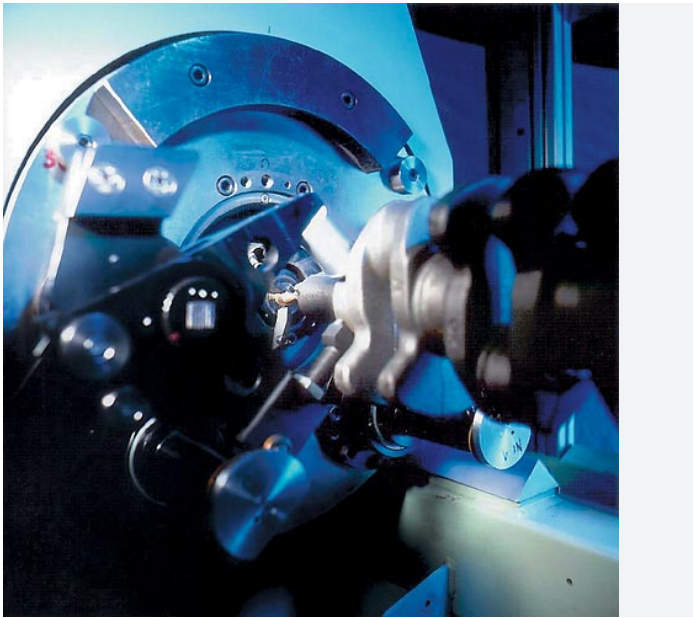

Measuring station for determining mass eccentricity by dynamic unbalance measurement. The crankshaft is loaded and unloaded from above, clamped at the main journals and driven between synchronous-rotating end discs by an amply dimensioned drive unit. Clamping and settling elements are easily exchanged for various crankshaft lengths. Adjuster gear with drive through separate stepper motors. Processing of asymmetric crankshafts by offset of the measuring unit. Single-station machines are equipped with integrated center-drilling units.

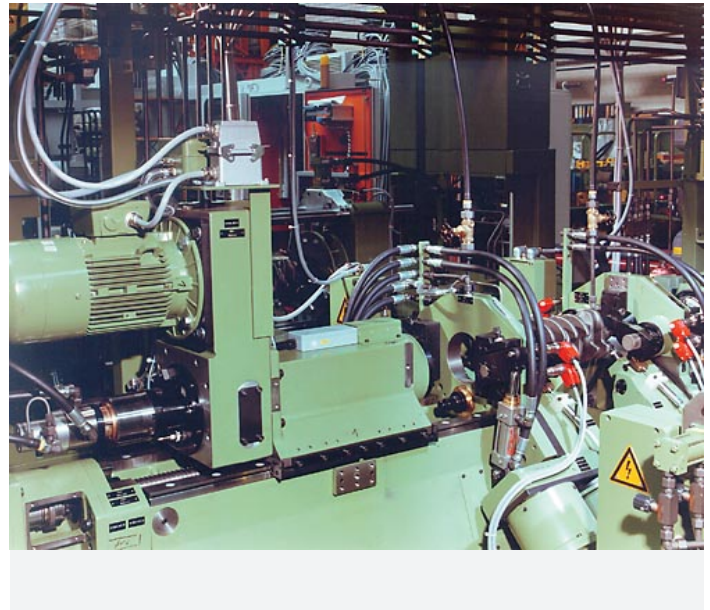

Drill units with hydraulic or electro-mechanical feed for drilling the center holes. Adjustable to various crankshaft lengths. Precision drill spindles for high centering accuracy. In the case of a separate centering station the crankshaft is clamped at the main journals and restrained by means of alignment elements. Adjustment to the optimum centering position is achieved by positioning motors, numerically controlled from the measuring equipment.



Mass-centering machines for vehicle crankshafts; high flexibility through sledge construction

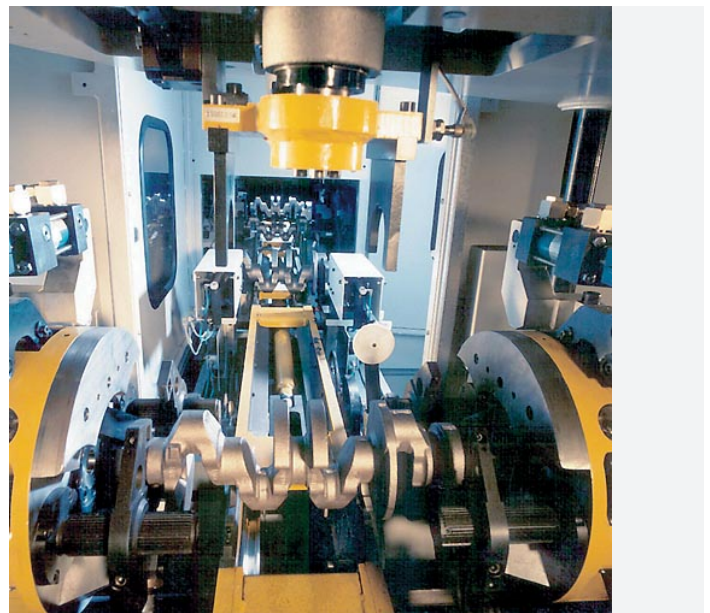

The multi-station TBTZ machine has an integrated lift and carry transporter. The modular design allows processing of crankshafts both before and after journal preparation. This way cutting to length, milling of stroke surfaces and mass-optimized end processing can be combined in a cost-effective manner.

400 SBRZ, 600 SBRZ, 400 TBTZ, 400 MBRZ Mass-Centering Machines for Crankshafts

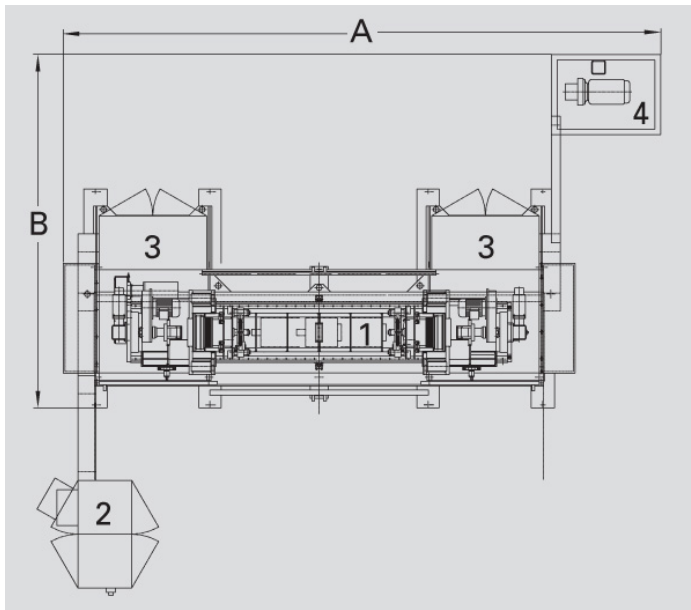

1 Centring balancing machine 2 Measuring device (operation) 3 Switch cabinet 4 Hydraulic assembly

Plan view (non-binding example: dimensions of the switch cabinet depend on the relevant application)

400 SBRZ, 600 SBRZ, 400 TBTZ, 400 MBRZ Mass-Centering Machines for Crankshafts

Technical data at a glance		400 SBRZ	400 TBTZ	400 MBRZ	600 SBRZ
Measuring unit		CAB 950	CAB 950	CAB 950	CAB 950
Passenger car crankshafts		•	•	•	
Crankshafts for light commercial					
vehicles and trucks					•
Asymmetrical crankshafts		•	•	•	•
Varying type programs		•	•	•	•
Automatic sequence of operations		•	•	•	•
Lifting device					•
Combined measurement and centering		•			•
Separate measurement and centering			•		
Measurement only				•	
Crankshaft forging or casting					
Weight	[kg]	7 - 50	7 - 50	7 - 50	40 - 200
Outside diameter, max.	[mm]	220	220	220	320
Main journal diameter	[mm]	45 - 80	45 - 80	45 - 80	70 - 130
Length	[mm]	360 - 780	360 - 790	360 - 790	500 - 1500
Machine					
Width A	[mm]	6700	3900	3900	7000
Depth B	[mm]	3000	4000	4000	4000
Height C	[mm]	2000	2000	2000	2600
Balancing speed	[min ⁻¹]	400	400	400	300
Clamping diameter	[mm]	45 - 120	45 - 120	45 - 120	60 - 180
Drill clamping diameter, max.	[mm]	25	25	-	25 / 32
Residual eccentricity	[mm]	0,06 - 0,07	0,06 - 0,07	-	0,06 - 0,07
Displacement, max.	[mm]	±4	±4	-	±5
Cycle time	[s]	45 - 80	25 - 32	23	50 - 80
Change-over time	[min]	1 - 30	1 - 50	1 - 30	1 - 45
Power consumption	[kVA]	17	20	12	19

Order No. R0630100.01 R0630300.01 R0630400.01 R0630200.01

Order No. R0630101.01 R0630301.01 R0630401.01 R0630201.01

Order No. R0630104.01 R0630304.01 - R0630204.01

A large industrial machine with a prominent rotating drum and various mechanical components, used for mass-centering crankshafts.

400 SBRZ, 600 SBRZ, 400 TBTZ, 400 MBRZ
Mass-Centering Machines for Crankshafts

-
- 2) Depending on weight, unbalance and drilling time (without loading and unloading)
 - 3) Data non-binding, depending on equipment supplied
 - 4) According to DIN 1319, 95% probability, relative to outer counter weights, mounting on center holes