

110 MBRS



CAB 690

CAB 690.

- 100

CAB 690

110 MBRS

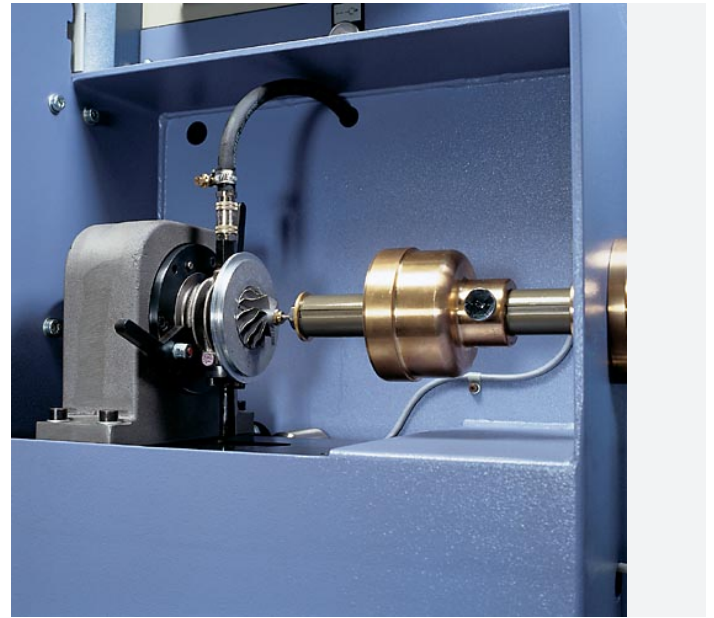

&

160;

&



160;



# 110 MBRS

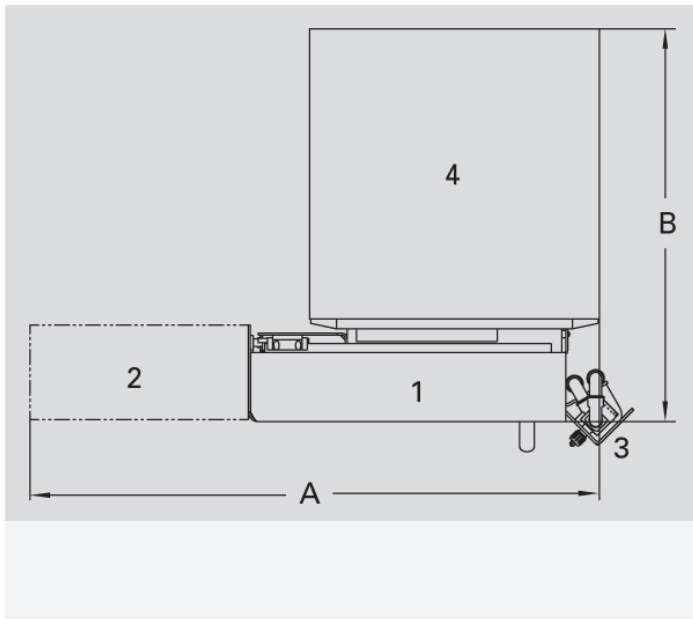

&

# 110 MBRS

Technical data at a glance		110 MBRS
Measuring unit		CAB 690
Automatic unbalance measurement		•
Manual unbalance correction		•
Manual rotor handling		•
<b>Passenger-vehicle turbochargers core assemblies</b>		
Weight, max.	[kg]	3
Flange diameter	[mm]	150
<b>Machine</b>		
Width A	[mm]	1500
Depth B	[mm]	900
Height C	[mm]	1700
Balancing speed, approx.	[min <sup>-1</sup> ]	250.000
Change over time	[min]	1 - 2
Air pressure	[kPa]	700
	Order No.	R0410100.01
	Order No.	o.r.
Correction tool	Order No.	R0410101.01
Printer	Order No.	R0410103.01
<b>Master assembly adapter</b>		
for prototypes	Order No.	o.r.

2) Data non-binding, dependent on the respective equipment

3) In the machine, correction on the shaft nut

o.r. On request