

460 KBTU Transfer Balancing Machine for Wound Armatures

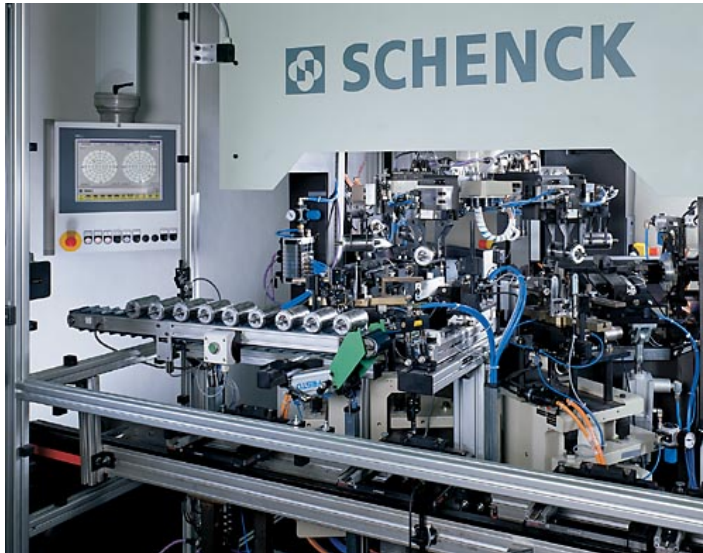

- Integrated overhead rotary transfer
- Machine base of mineral casting with good damping characteristics
- Automatic sequence, secured, controlled by Soft PLC
- NC axes for all movements
- Integration with production lines
- Powerful PC based industrial measuring unit
- Photo based operating manual for conversion of machine
- Picture and text based fault diagnosis
- Teleservice for measuring and control system

Range of application

Measurement and correction of unbalance of armatures of various sizes. Use of the machine in production lines for very high production volumes. Unbalance correction by milling into the stack (profile/slot milling) in one or two planes.

Design

Six-station machine with fully automatic sequence of operations. Station-to-station transfer and integration with peripheral equipment through integrated rotary transport. Work-pieces can be delivered to the machine by conveyor or pallet.

Correction methods

Profile milling:
Polar unbalance correction at the correct angle, suitable for most applications.

Polar slot milling:
The milling spindle with twin cutter is displaced axially to shift the effect of the milling operation to the polar direction of the unbalance.

Slot milling:
A variable method for quasi-polar or component correction. High flexibility through employment of single or multiple cutters and adaptation of the component angle. All correction methods can be used for armatures with inclined or straight stack slots. In addition to material removal by plunge milling, weight removal can be increased by controlled axial cutter advancing.

460 KBTU Transfer Balancing Machine for Wound Armatures

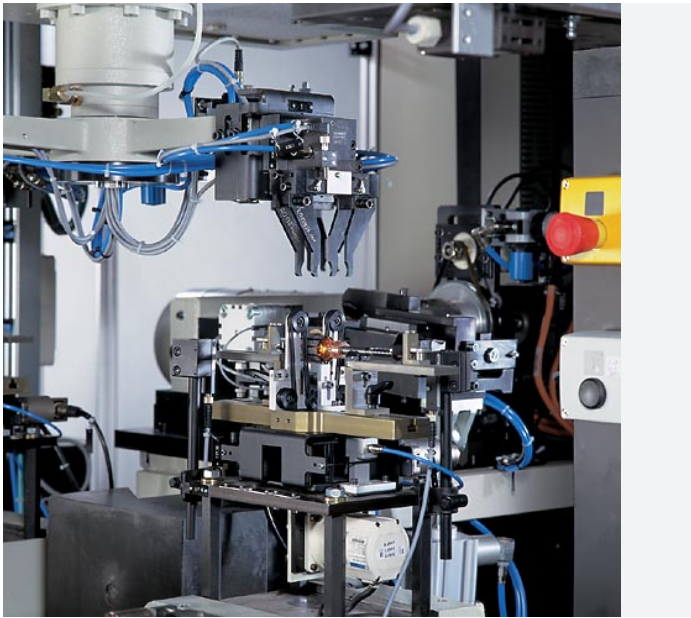

The balancing unit has a belt-drive with AC servo-motor, precision electro-dynamic vibration sensors and support pedestals with V-block or roller carriages. All work-piece contacting parts are equipped with revolving head stops for fast height and length adjustments. The electronic angle reference sampling system operates extremely accurately and requires no separate reference mark.

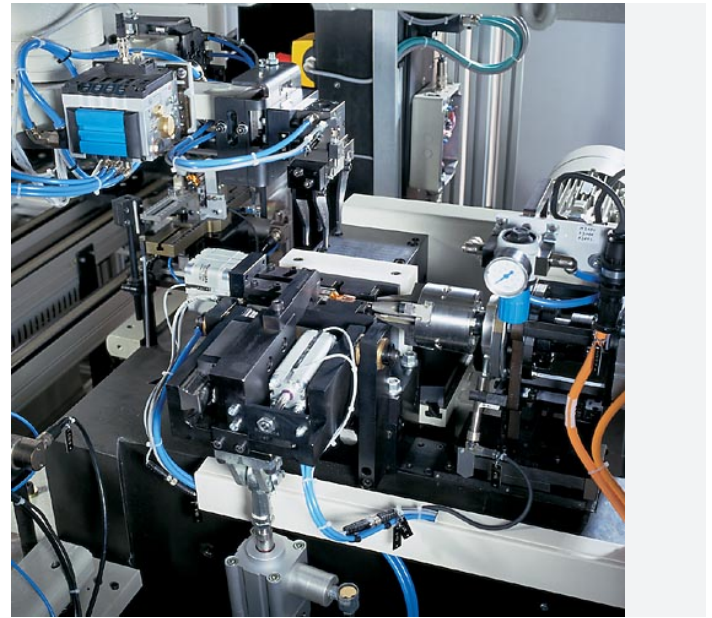

Flexible application and easy change over of the correction station as well: its digital controlled milling and positioning equipment operates effectively and accurately, and also permits the desired milling method to be selected. Whether profile milling or slot milling in components, plunge or axial milling, this machine is designed for any processing format.

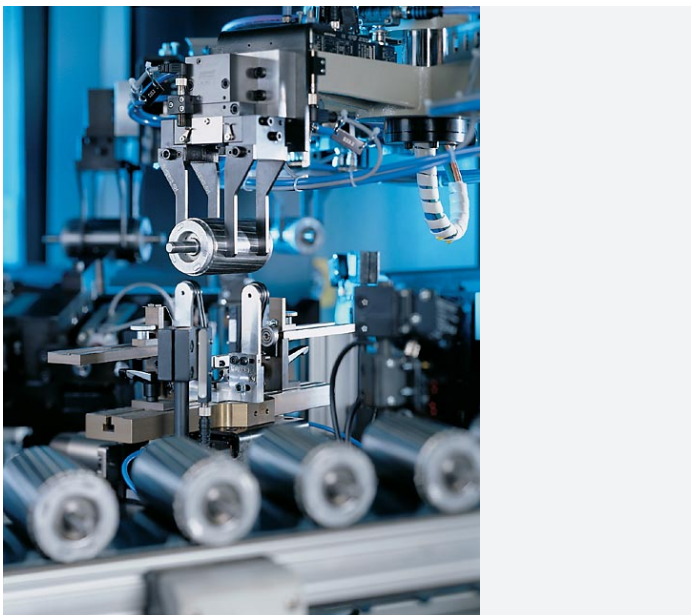

The transport operates with a lift-and-turn gear and is regulated by a frequency-controlled drive. In a flowing, sine-wave motion the rotors are safely transferred through the stations. This ensures short cycle times with smooth acceleration, and exact positioning. We offer a variety of customized solutions for integration with existing production lines and the sorting of out-of-tolerance rotors.

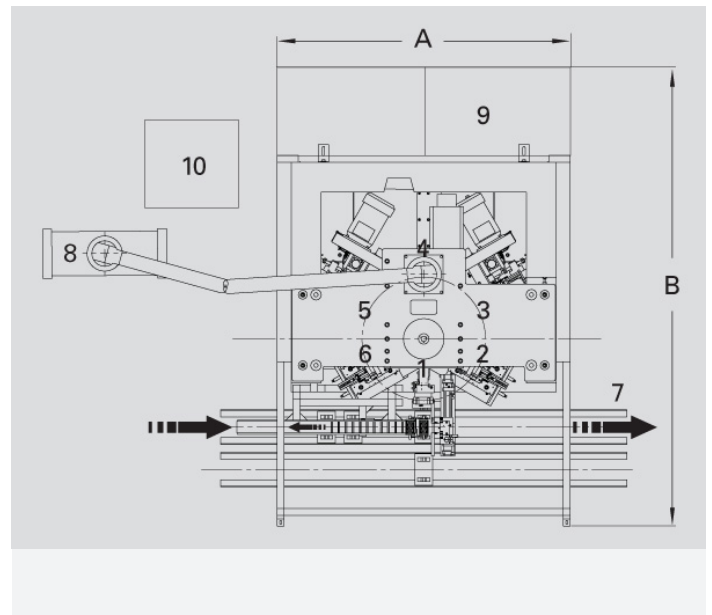

- 1 Pick-up/transfer device
- 2 Measuring station
- 3 Correction station Plane 1
- 4 Indexing station
- 5 Correction station Plane 2
- 6 Control station
- 7 Interlinking (on request)
- 8 Measuring system, positioning control
- 9 Switch cabinet
- 10 Swarf extractor (option)

460 KBTU

Transfer Balancing Machine for Wound Armatures

Technical data at a glance		461 KBTU	462 KBTU	463 KBTU
Measuring unit		CAB 850	CAB 850	CAB 850
Polar profile milling		•		
Slot milling in components			•	
Polar slot milling				•
Commutator armatures				
Weight	[kg]	0,1 - 2	0,1 - 2	0,1 - 2
Diameter	[mm]	24 - 82	24 - 66	24 - 40
Length	[mm]	69 - 250	90 - 250	90 - 190
Stack height	[mm]	12 - 65	30 - 65	30 - 50
Machine				
Width A	[mm]	1660	1660	1660
Depth B	[mm]	2600	2600	2600
Height C	[mm]	2780	2780	2780
Balancing speed	[min ⁻¹]	1500 - 2100	1500 - 2100	1800 - 2100
Measuring uncertainty	[gmm]	0,02 - 0,1	0,02 - 0,1	0,02 - 0,1
Achievable tolerance	[gmm]	0,4	0,1	0,2
Cycle time(plunge-milling)	[s]	4,5 - 5,0	6 - 7	4,5 - 5,0
Cycle time (axial-milling)	[s]	5,5 - 6,0	7 - 8	5,5 - 6,0
Change-over time	[min]	5 - 15	5 - 15	5 - 15
Air pressure	[kPa]	450	450	450
Air consumption	[m ³ /h]	3,0	3,0	3,0
Power consumption	[kVA]	15	15	15

	Order No.	R0210100.01	R0210200.01	R0210300.01
	Order No.	-	R0210203.01	-
Chip extractor	Order No.	R0210104.01	R0210204.01	R0210304.01

2) Data non-binding, dependent on the respective equipment supplied

3) Rotor-dependent