

## 200 KBTK Transfer Balancing Machine for Crankshafts



- Fully automatic sequence of operations
- Integrated exchange transporter
- Integration with production lines possible
- NC axis control for correction
- Optimized correction
- High-speed drilling with minimum lubrication or coolant lubrication

### Design

Two-station machine with automatic cycle for measurement, correction and checking procedures. Compact machine design, easily integrated into production.

Linking of stations through rotary exchange transporter. Welded machine base, station and exchange transport. Microprocessor-controlled measuring equipment for calculating the optimum correction. Software programs for component correction or optimized correction and statistics. Programmable machine control and machine diagnostic system for shortening machine down time are supplied as standard (display in German and English). Manual loading through suitable lifting device or an existing loading system, e.g. a loading gantry supplied by the customer.

### Range of application

Measurement and correction of unbalance in machined crankshafts for passenger-vehicle and light commercial-vehicle crankshafts.

Use of the machine in large volume production, integrated into a production line.

Unbalance correction by drilling into the counterweights in one or two correction steps.

### Sequence of operations

- Load crankshaft A into the measuring station by hand or external conveyor device.
- Unbalance measurement of shaft A in two planes, relative to the outside counterweights. If necessary convert negative unbalance values to other correction planes. Store the values for correction. Index the crankshaft to the home position.
- Simultaneous correction of a previously measured crankshaft B in the correction station.
- Pick up and exchange of both crankshafts by the machine transport. Load crankshaft A into correction station. Index to the 1st correction component, clamp, drill the unbalance value in the 1st correction step, index to the 2nd component and drill again.
- Simultaneously check the residual unbalance of crankshaft B. Remove the balanced crankshaft B from the measuring station by hand or the external conveyor device. Load the new crankshaft C.
- Pick up and exchange of both crankshafts by the machine transport.

## 200 KBTK Transfer Balancing Machine for Crankshafts

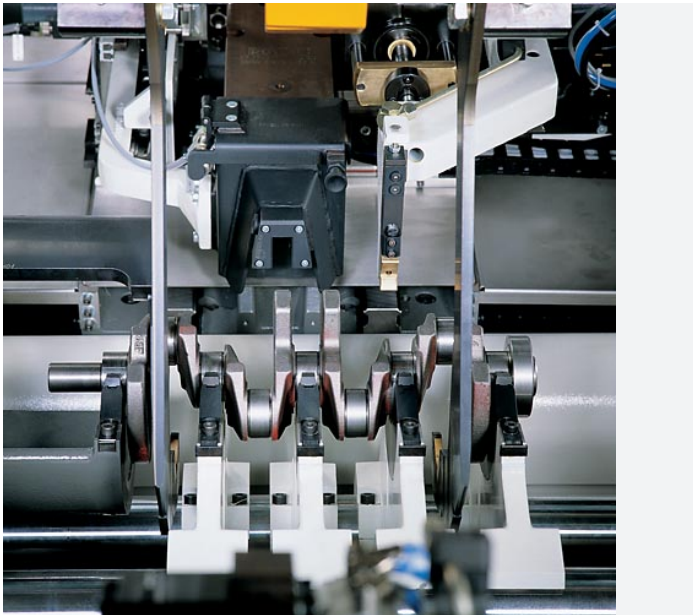

Correction station with easily-accessed, horizontally-arranged drill unit with electromechanical feed mechanism. Precision drill-touch point and depth-control. Drilling with coolant or minimum lubrication. Clamping unit arranged as a totally enclosed fixture to eliminate machine contamination by coolant or chips. Chip removal by underfloor chute or conveyor.

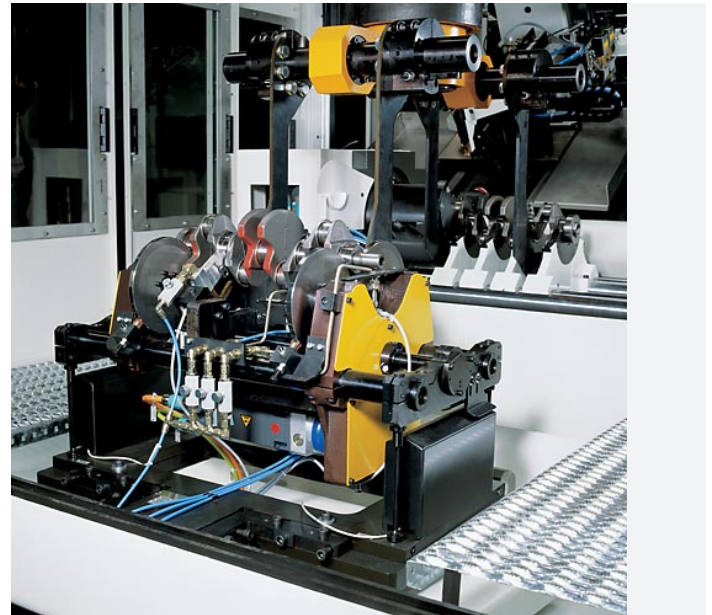

Measuring station with coupling-free drive. Drive to the crankshaft supplied by synchronous driven rollers with hardened metal coating. Non-contacting crank pin detection for the angle reference. Adaptability through variable distance between roller pairs.

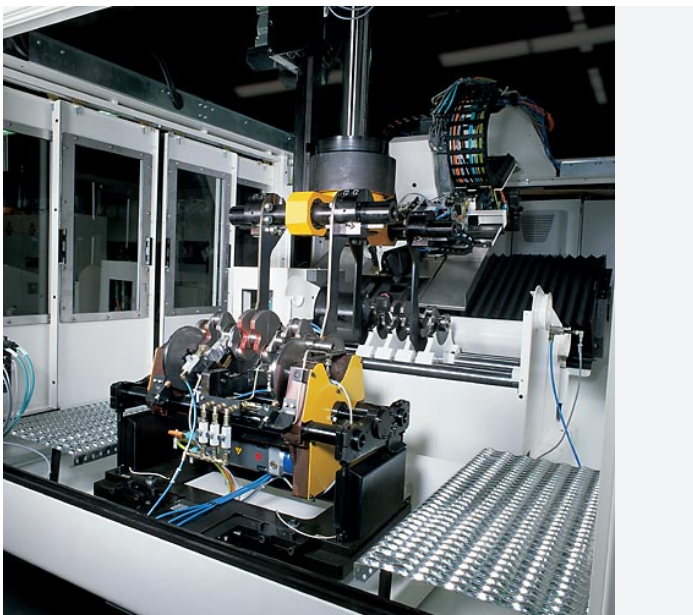

Both stations of the machine covered by the rotary-lifter transport with transport hooks. Short cycle times with minimum mass movement and short travel distances.

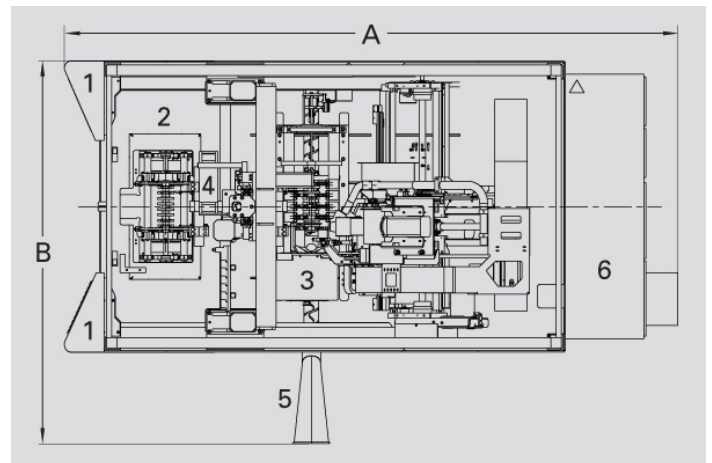

1 Operating panel 2 Measurement and control station 3 Correction station 4 Transfer 5 Swarf removal 6 Switch cabinet

## 200 KBTK Transfer Balancing Machine for Crankshafts

Technical data at a glance		220 KBTK	220 KBTK
Measuring unit		CAB 950	CAB 950
Optimized correction		•	•
Balancing unit with roller-drive		•	
Balancing unit with hook-drive for asymmetric crankshafts			•
Number of stations		2	2
<b>Crankshafts</b>			
Dimensions		see table on page 81	see table on page 81
<b>Machine</b>			
Width A	[mm]	3480	3480
Depth B	[mm]	5550	5550
Height C	[mm]	3000	3000
Measurement uncertainty	[gmm]	see table on page 81	see table on page 81
Cycle time	[s]	45 - 100	45 - 100
Air pressure	[kPa]	600	600
Power consumption	[kVA]	20	20
	Order No.	R0300200.01	R0300300.01
	Order No.	R0300201.01	R0300201.01
Geometry measuring station for crank pins	Order No.	R0300202.01	R0300202.01
Multi-spindle drill unit, sprung	Order No.	R0300204.01	R0300204.01
Chip-conveyor	Order No.	R0300205.01	R0300205.01

2) Data non-binding, dependent on respective equipment supplied

3) Dependent on crankshaft and correction scheme